

STEP 3: Insert Straight Hooks into the pre-drilled holes on the outside of the Vertical Bars. Secure Caps on the Vertical Bars and Cross Bars. See *Figure 3*.

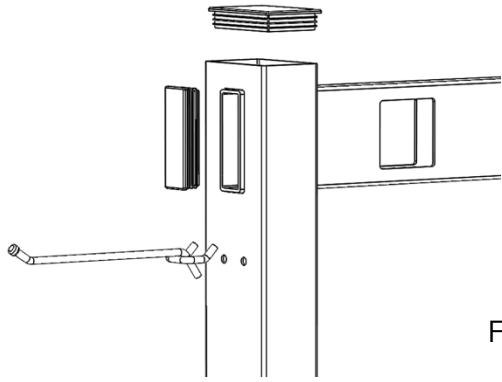

Figure 3

STEP 4: Center and secure the Magnetic Display Sign Clip on top of the Cross Bar and attach Display Sign facing the frontside. See *Figure 4*.

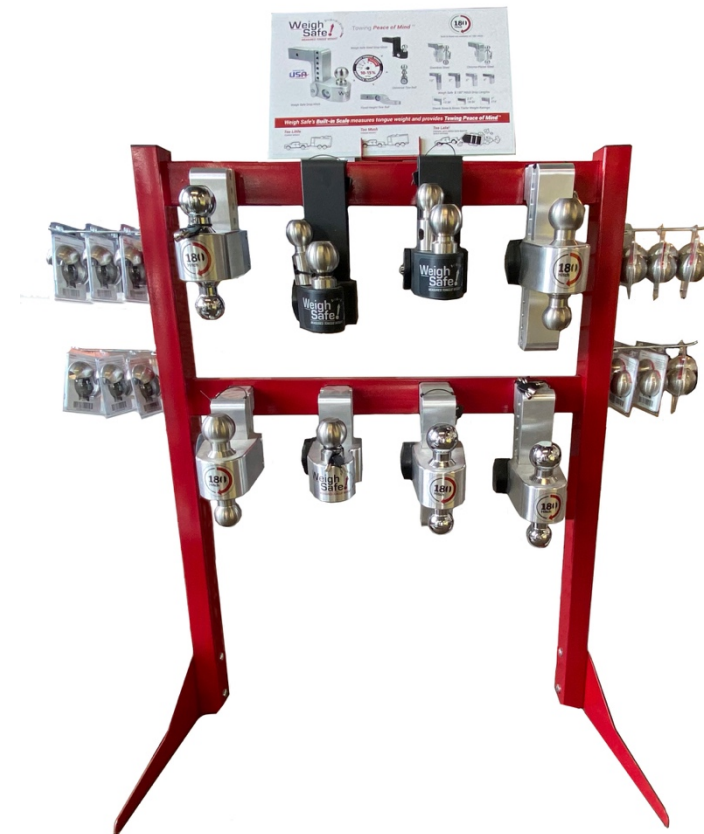

Figure 4

For further questions and/or assistance, please contact our Customer Support team via text/call at 801.820.7020 or via email at support@weigh-safe.com.



POP-HSXL Instruction Manual



www.weigh-safe.com

PARTS

PART	QTY
Vertical Bar	2
Cross Bar	2
Foot Plate	2
Cross Bar Bolt (1 1/2 ")	8
Vertical Bar Bolt (2 3/4 ")	4
Nut	12
Washer	4
Straight Hook	4
Cross Bar Cap	4
Vertical Bar Cap	2
Magnetic Display Sign Clip	1
Display Sign	1

STEPS

STEP 1: Lay both Vertical Bars on the floor with the four pre-drilled holes laying on the ground (this is the backside). Align the holes on the Foot Plate with the holes on the outside of the Vertical Bar; the elongated portion of the Foot Plate should be facing the front. Insert Vertical Bar Bolts from the inside to the outside of the bar and secure with washers and nuts. See *Figure 1*.

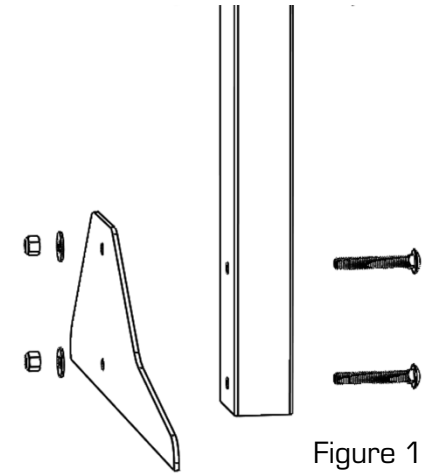

Figure 1

Repeat for the second Vertical Bar.

STEP 2: Insert the Cross Bar into the designated opening on the Vertical Bar with the pre-drilled holes facing the backside. Align the holes on the Cross Bar with the holes on the Vertical Bar. Insert Cross Bar Bolts from the

backside to the middle of the Cross Bar tube and secure with nuts. See *Figure 2*.

Repeat for remaining Cross Bar.

Repeat STEP 2 on the remaining Vertical Bar.

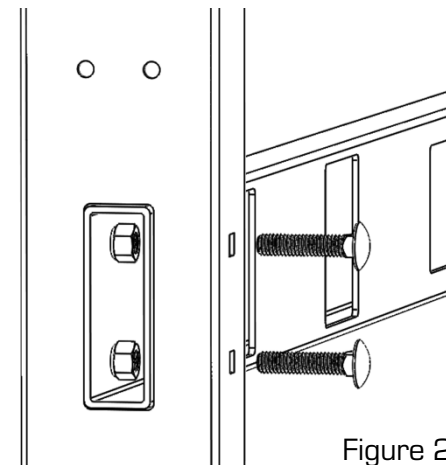

Figure 2

